

Intrinsically safe solenoid valves

on/off controls - ATEX or IECEX certification

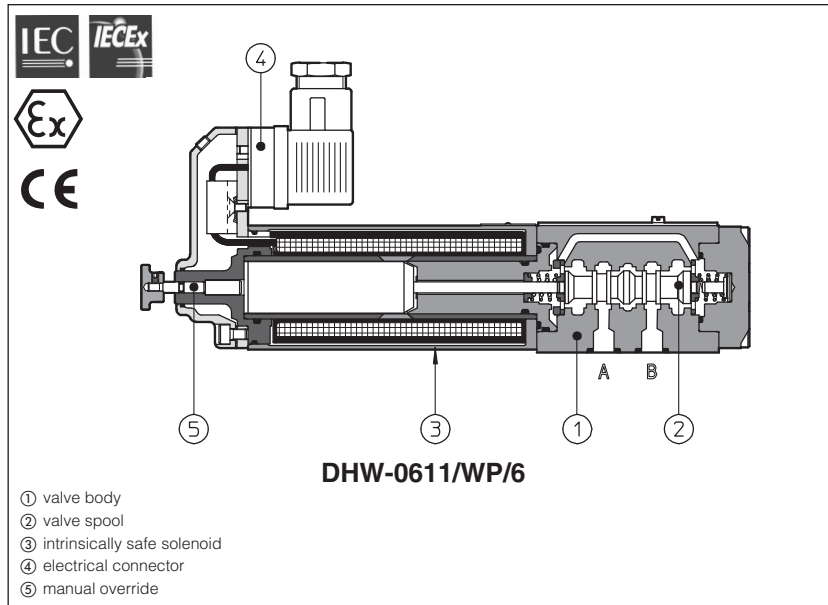

On/off valves equipped with intrinsically safe solenoids available with following certifications and protection modes:

Solenoids group II for surface plants with gas environment category 1, zone 0, 1 and 2

- ATEX 94/9/CE, Ex II 1 G, Ex ia IIC T6 (IIB T6 or IIA T5)
- IECEX, worldwide recognized safety certification Ex ia IIC T6 (IIB T6, IIA T5) Ga

Solenoids group I for surface, tunnels or mining plants

- ATEX 94/9/CE, Ex I M2 Ex ia I
- IECEX, worldwide recognized safety certification Ex ia (ib) I Mb

The "intrinsically safe" protection is based on the principle of limiting the energy of electric circuits in environments with presence of hazardous atmospheres. For this reason the valves must be supplied through specific "safety barriers" limiting the max current to the solenoid. Atos provides galvanically insulated barriers for single and double solenoid valves, see section 18 to 21. The "intrinsically safe" circuit is virtually unable to produce electrical surges or thermic effects able to cause explosion in hazardous environments also in presence of specific break-down situations.

1 INTRINSICALLY SAFE SOLENOIDS: MAIN DATA

Solenoid code	Group II ATEX	OW-18/6	OW-18/H
	Group I ATEX (mining)	OWM-18/6	OWM-18/H
	Group II IECEX	OWI-18/6	OWI-18/H
	Group I IECEX (mining)	OWIM-18/6	OWIM-18/H
Nominal resistance at 20°C	150 Ω		
Coil insulation	Class H		
Protection degree	IP66	IP67	
Duty factor	100%		
Electrical connector	DIN 43650 2 pin+GND	MIL-C-26482 3 pin	

2 INTRINSICALLY SAFE SOLENOIDS: ELECTRICAL AND TEMPERATURE DATA

Method of protection	Ex ia / Ex ib according to EN60079-0: 2006, EN60079-11:2007						
Gas group	I and IIC			I and IIB	I and IIA	I	
Temperature class	T6			T6	T5	-	
Electrical characteristic	V max	27 V	19,5 V	19,11 V	28 V	28 V	12,4 V
	I max	130 mA	360 mA	360 mA	250 mA	396 mA	2200 mA
	P max	0,9 W	1,64 W	1,72 W	1,8 W	2,8 W	6,82 W
Minimum supply current	≥ 65mA, for I.S. barriers see section 18 to 21						
Surface temperature (ambient temp. +60°C)	≤ 85°C				≤ 100°C		150 °C
Ambient temperature	-40 ÷ +60°C (1)					-20 ÷ +60°C	

(1) The group II solenoids are ATEX certified for minimum temperature -40°C. Select /BT in the valve code for the application with minimum temperature -40°C

3 CERTIFICATIONS

In the following are resumed the valves marking according to the Atex and IECEx Group I and Group II certification:

3.1 GROUP II, Atex

- Ex** = Equipment for explosive atmospheres
- II** = Group II for surface plants
- 1** = Very high protection (equipment category)
- G** = For gas and vapours
- ia** = Intrinsically safe execution
- IIC, IIB, IIA** = Gas group - applications or surface plants
- T6 / T5** = Temperature class of the solenoid surface referred to +60°C ambient temperature
- Ga** = Equipment protection level >1000 hrs/y in explosive atmosphere
- IP66** = High protection from dust and water jets
- Zone 0** (1 and 2) = Explosive atmosphere continuously present

EXAMPLE OF NAMEPLATE MARKING

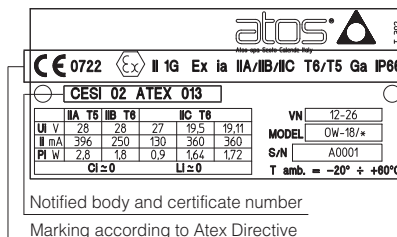

3.2 GROUP I Atex (mining)

- Ex** = Equipment for explosive atmospheres
- I** = Group I for mines and surface plants
- M2** = High protection (equipment category)
- ia, Ib** = Intrinsically safe execution
- I** = Gas group (Methane)
- Mb** = Equipment protection level, high level protection for explosive atmospheres
- IP66** = High protection from dust and water jets

EXAMPLE OF NAMEPLATE MARKING

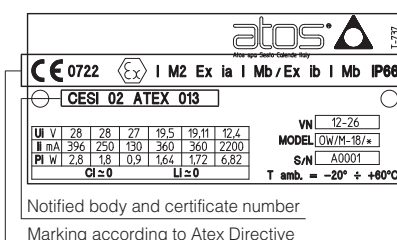

3.3 GROUP II IECEx

- Ex** = Equipment for explosive atmospheres
- ia** = Intrinsically safe execution
- IIC, IIB, IIA** = Gas group - applications or surface plants
- T6, T5** = temperature class of solenoid surface referred to +60°C ambient temperature
- Ga** = Equipment protection level >1000 hrs/y in explosive atmosphere
- IP66** = High protection from dust and water jets

EXAMPLE OF NAMEPLATE MARKING

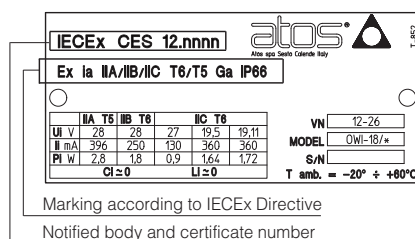

3.4 GROUP I IECEx (mining)

- Ex** = Equipment for explosive atmospheres
- ia (Ib)** = Intrinsically safe execution
- I** = Gas group (Methane)
- Mb** = Equipment protection level, high level protection for explosive atmospheres
- IP66** = High protection from dust and water jets

EXAMPLE OF NAMEPLATE MARKING

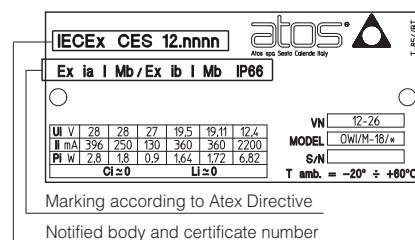

4 MAIN CHARACTERISTICS OF INTRINSICALLY SAFE VALVES

Assembly position	the installation of DHW valves with the axis in vertical position is not recommended. If this type of installation is absolutely necessary, please consult our technical office
Subplate surface finishing	Roughness index Ra 0,4 - flatness ratio 0,01/100 (ISO 1101)
Ambient temperature	Standard execution = -30°C ÷ +70°C /PE option = -20°C ÷ +70°C /BT option = -40°C ÷ +70°C
Seals, recommended fluid temperature	NBR seals (standard) = -20°C ÷ +60°C, with HFC hydraulic fluids = -20°C ÷ +50°C FKM seals (/PE option) = -20°C ÷ +80°C HNBR seals (/BT option) = -40°C ÷ +60°C, with HFC hydraulic fluids = -40°C ÷ +50°C
Fluid	Hydraulic oil as per DIN 51524 535; for other fluids see section 5
Recommended viscosity	15 ÷ 100 mm²/s at 40°C (ISO VG 15 ÷ 100) max viscosity 400 mm²/s
Fluid contamination class	ISO 4406 class 20/18/15 NAS 1638 class 9, in line filters of 10 µm (β ₁₀ ≥ 75 recommended)
Fluid temperature	-20°C +60°C (standard and /PE seals) -40°C to +60°C for /BT option -20°C to +80°C for /PE option

4.1 Corrosion protection characteristics

Valve screws: all screws made in stainless steel class A2

5 MODEL CODE OF SPOOL TYPE ON-OFF DIRECTIONAL SOLENOID VALVES

DH	W	/*	- 0	71	3H	/ A	/ 6	**	/*
DH = spool type - direct DPH = spool type - piloted W = intrinsically safe solenoid, Atex certified omit for Atex Group II M = Atex Group I (mining) IE = IECEx Group II IEM = IECEx Group I (mining) Valve size (ISO 4401): for DHW: 0 = size 06; for DPHW: 1 = size 10 2 = size 16; 4 = size 25								Seals material, see sect. 4: - = NBR PE = FKM BT (2) = HNBR Series number Connector type - see section 7 /6 = DIN 43650 (standard) /H = MIL-C-26482	
								Options: /A = solenoid at side of port B /WP = prolonged manual override Only for DPHW /D = internal drain /E = external pilot pressure /H = adjustable chokes (meter-out to the pilot chambers of the main valve) /L9 = (only for DPHA-2 and DPHA-4) plug with calibrated restrictor on port P of pilot valve	
								Spool type, DHW see section 6 and DPHW see section 7 3H = spool type 3H for marine applications (1) Only for DHW-071	

Valve configuration, DHW see section 6 and DPHW see section 7

- (1) Spool type 3H provides larger passages A-B to T in central position than spool type 3, see section 11.3
 (2) Not for group I Atex -mining

6 HYDRAULIC CONFIGURATIONS OF DHW VALVES

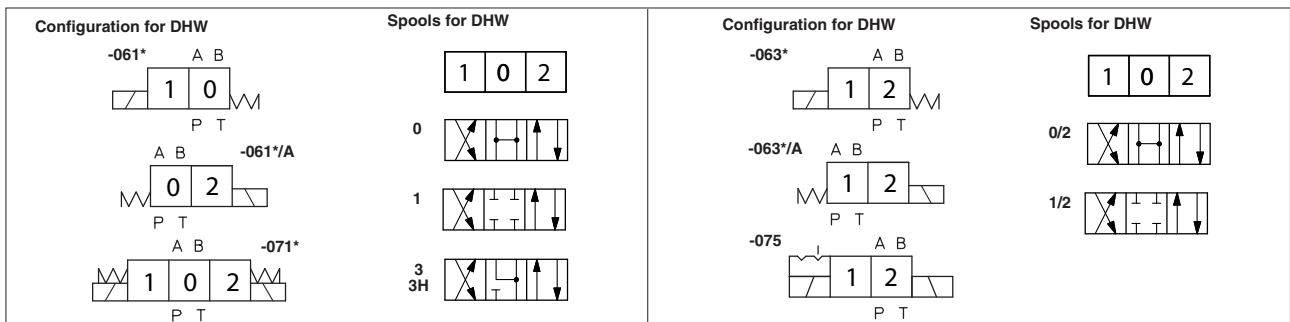

7 CONFIGURATION OF DPHW VALVES

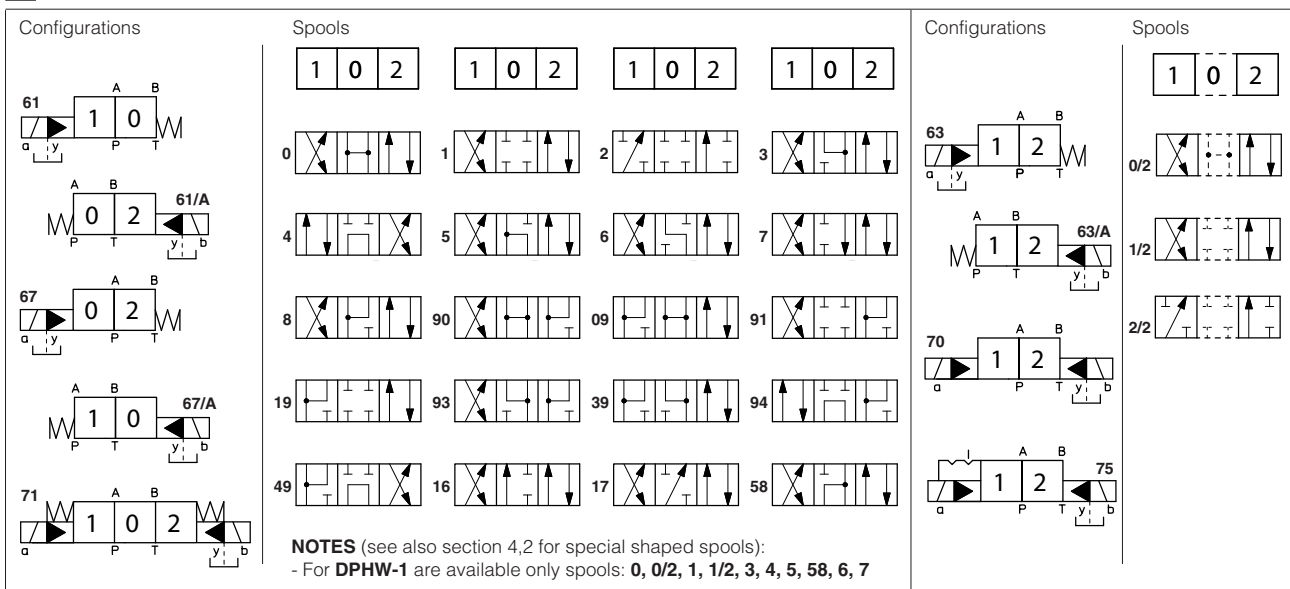

8 MODEL CODE OF POPPET TYPE LEAK FREE ON-OFF DIRECTIONAL SOLENOID VALVES

DLOH / * - 2 A / R - WO / 6 ** / *

directional control valve, poppet type size 06
omit for Atex Group II
M = Atex Group I (mining)
IE = IECEx Group II
IEM = IECEx Group I (mining)

2 = 2 way **3** = 3 way

A = open in rest position **C** = closed in rest position

Options:
/R = with check valve on port P
/WP = prolonged manual override

(1) Not for group I Atex -mining

Seals material, see sect. 4:
- = NBR
PE = FKM
BT (1) = HNBR

Series number

Connector type - see section 17
/6 = DIN 43650 (standard)
/H = MIL-C-26482

WO = intrinsically safe solenoid

9 HYDRAULIC CONFIGURATIONS OF DLOH VALVES

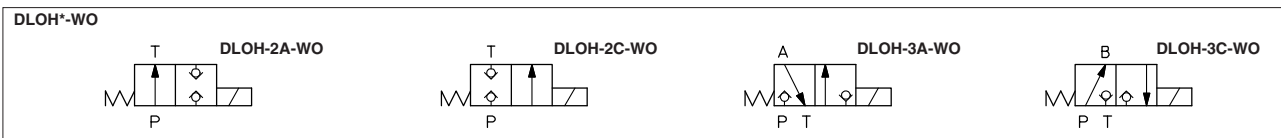

10 Q/Δp DIAGRAMS based on mineral oil ISO VG 46 at 50°C

DHW

spool type	0	0/2	1/2	1	3	3H
Flow direction						
P→A / P→B	4	5	5	3	3	3
A→T / B→T	6	2	1	2	4	5

DLOH*-WO

configuration	2A	2C	3A	3C
Flow direction				
P→A / P→B (1)	1	2	4	3
A→T / B→T	-	-	5	4

(1) For two-way valves pressure drop refers to P→T

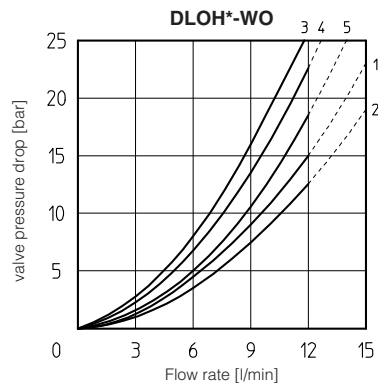
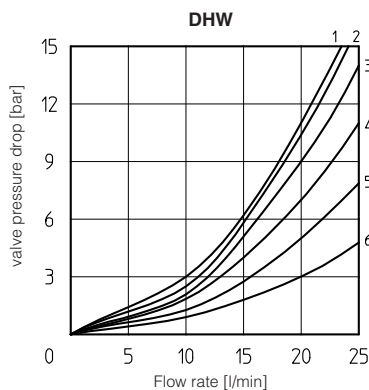

11 OPERATING LIMITS based on mineral oil ISO VG 46 at 50°C

The diagrams refer to warm solenoids and power supply provided by the Atos barrier type **Y-BXNE-412**. For DHW valves the curves refer to application with symmetrical flow through the valve (i.e. P → A and B → T). In case of asymmetric flow the operating limits must be reduced.

DHW type	0	0/2	1/2	1	3	3H
Diagram	B	B	C	C	A	D

DLOH type	2A	2C	3A	3C
Diagram	G	G	F	E

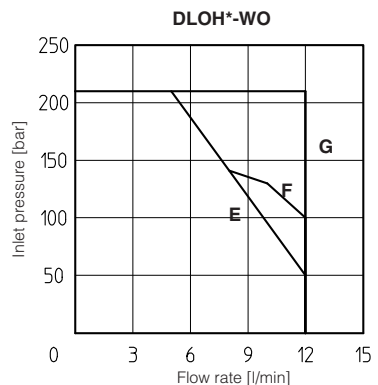
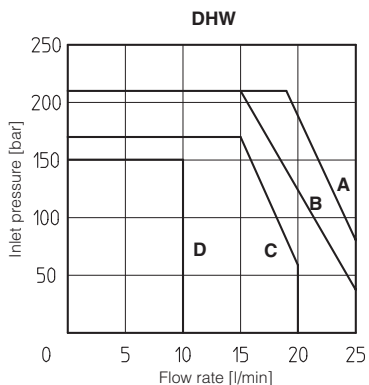

11.1 Operating pressure:

Ports P, A, B = 350 bar Port T = 160 bar

11.2 Operating limits (only for DHW-0713H)

Max flow = 10 l/1' - Max pressure = 150 bar

11.3 Flow capability in central position A-B → T (only for DHW-0713H)

Max flow = 25 l/1' with Δp 10,5 bar

12 INTERNAL LEAKAGES

12.1 DHW internal leakages

18 cm³/min with P=100 bar - fluid viscosity = 43 cSt at 40 °C
30 cm³/min with P=140 bar - fluid viscosity = 22 cSt at 45 °C

12.2 DLOH*-WO internal leakages based on mineral oil ISO VG 46 at 50°C

less than 5 drops/min (0,36 cm³/min) at max pressure.

13 MODEL CODE OF PRESSURE CONTROLS

AGAM

/* - 20 / 2 0 / 210 - WO / WP / 6 ** /*

AGAM = pressure relief valve, subplate mounting, see tab. C066
ARAM = pressure relief valve, threaded connections, see tab. C045

omit for Atex Group II
M = Atex Group I (mining)
IE = IECEx Group II
IEM = IECEx Group I (mining)

Valve size
 for AGAM: **10** = size 10 (ISO 6264); **20** = size 20 (ISO 6264); **32** = size 32 (ISO 6264);
 for ARAM: **20** = G 3/4"; **32** = G 1 1/4"

Number of the different setting pressure values:
1 = one setting pressure
2 = two setting pressure
3 = three setting pressure

(1) Not for group I Atex -mining

Seals material, see sect. 4:
 - = NBR
PE = FKM
BT (1) = HNBR

Series number

Connector type - see section 17

/6 = DIN 43650 (standard)
/H = MIL-C-26482

Option:

/WP = prolonged manual override

WO = Intrinsically safe solenoid

Pressure range of first/second/third setting:
50 = 4 - 50 bar **210** = 7 - 210 bar
100 = 6 - 100 bar **350** = 8 - 350 bar

Valve configuration
0 = venting with de-energized solenoid
1 = venting with energized solenoid
2 = without venting

14 HYDRAULIC CHARACTERISTICS

Valve model	AGAM-10-WO	AGAM-20-WO	AGAM-32-WO
Max pressure [bar]		350	
Setting		50; 100; 210; 350	
Pressure range [bar]		4÷50; 6÷100; 7÷210; 8÷350	
Max flow [l/min]	200	400	600

15 MODEL CODE OF COVERS FOR CARTRIDGE VALVES

LIDEW

/* 1 - 1 / * - WO / 6 ** /*

Cover type:
LIDBH = with solenoid valve and shuttle valve for pilot selection
LIDEW = with solenoid valve

omit for Atex Group II
M = Atex Group I (mining)
IE = IECEx Group II
IEM = IECEx Group I (mining)

Valve configuration, see section 16

Valve size (ISO 7368)
 for LIDBH*: **1** = 16, **2** = 25, **3** = 32, **4** = 40, **5** = 50
 for LIDEW* **1** = 16, **2** = 25, **3** = 32, **4** = 40, **5** = 50, **6** = 63

Seals material, see sect. 4:
 - = NBR
PE = FKM
BT (1) = HNBR

Series number

Connector type - see section 17
/6 = DIN 43650 (standard)
/H = MIL-C-26482

WO = Intrinsically safe solenoid

Options:
/B = cartridge piloted via port "B" of solenoid pilot valve
/E = external attachments X (G 1/4") and underneath port X supplied plugged (only for sizes 40 to 80)

Note: for the code of the ISO cartridge to use with the above covers see tab. H003, section 2 and tab. H030, section 3.

(1) Not for group I Atex -mining

16 HYDRAULIC SYMBOLS

17 SOLENOID DIMENSIONS AND WIRING

Dimension [mm]

OW-18/6 (standard) Option /H Option /WP

80.5
104 min.
45
manual override pin
131.5
5
131.5
12
ø 16

Connector wiring		
/6	/H	Connections
1	A	Coil
2	C	Coil
3	B	GND

DIN 43650

MIL-C-26482

cover shape for mining version

1 (A)
2 (C)

note: the connectors are supplied with the valves

18 INTRINSICALLY SAFE BARRIERS

The electric supply to these solenoids must be done through electronic devices situated out of potentially flammable environment (i.e. in safe zone), which limit the electric current to the intrinsically safe solenoid. These electronic devices are normally called "intrinsically safe barriers" approved and certified according to the Ex ia protection mode. To select the proper intrinsically safe barriers following data must be considered:

- 1) V_{max} and I_{max} of the solenoid as specified in section 2 must not be exceeded also in fault conditions;
- 2) the resistance of the solenoid is 150 Ω and the current supplied by the barrier, in normal operation condition, must be over the min. limit (65 mA) to ensure the valve correct operation (over 70 mA for max performances).

The barriers type Y-BXNE 412 are galvanically isolated electronic devices, developed according to the European Norms EN60079-0/06, EN60079-11/07 and certified ATEX 94/9/CE, protection mode Ex ia IIC.

These barriers ensure the optimized functioning of the Atos valves up to the max operating limits specified in section 11.

The barriers Y-BXNE-412 are double channel type, suitable to operate valves with double or single solenoid.

Two single solenoid valves can be connected to the barrier (one to each channel) but they cannot be contemporary operated.

19 MODEL CODE OF I.S. BARRIER

**19.1 I.S. barrier for double solenoid valves
Y-BXNE 412 00 ***

Supply voltage
E = 110/230 VAC
2 = 24÷48 VDC

The above barrier can be used both for double or for single solenoid valves.
 With one barrier, two single solenoid valves can be operated but not contemporary, see section 18.

20 TECHNICAL CHARACTERISTICS OF I.S. BARRIER

	Y-BXNE 412
N° output channels	2
Power supply voltage	110÷230 VAC \pm 10% (50/60 HZ) 21,6 \pm 53 Vdc
Power consumption	< 3W
Output voltage U_o	19,5 V
Output current I_o	341 mA
Output power P_o	1,64 W
Galvanic insulation supply/output	2500 VAC / 50 Hz
Storage temperature	-25 °C \div +70 °C
Working temperature	-10 °C \div +60 °C
Housing material	ABS case
Mounting	on rail EN 50022
Electrical connections	screw terminals
Method of protection	Ex ia IIC
ATEX classification	Ex II 1 G/D

21 INSTALLATION DIMENSIONS OF I.S. BARRIER [mm]

Y-BXNE 412

Power On led
 Sol. A enabled led
 Sol. B enabled led

80
21.5
135
88
108

M L J H
 + - + -
 A B C D E F

Y-BXNE 412

Safe zone Hazardous zone

Power supply - Vdc/~
 + Vdc/~

Input command Sol. A
 +24 VDC
 GND

Input command Sol. B
 +24 VDC
 GND

M J L H
 Sol. A
 Sol. B

ISO 4401: 2005
Mounting surface: 4401-03-02-0-05 (see table P005)
(for Y version, surface 4401-03-03-0-05 without X port)

Fastening bolts: 4 socket head screws M5x50 class 12.9
 Tightening torque = 8 Nm
 Seals: 4 OR 108; 1 OR 2025
 Diameter of ports A, B, P, T: \varnothing 7,5 mm (max)
 Diameter of port Y: \varnothing = 3,2 mm (only for Y option)

DLOH

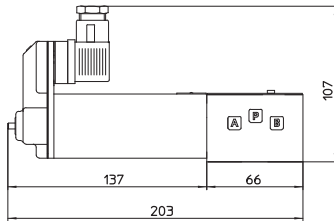

DHW

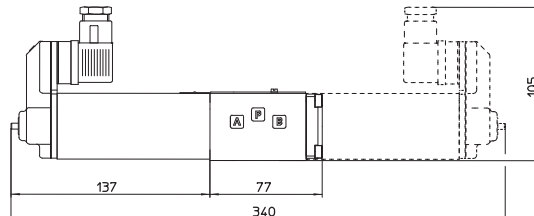

ISO 4401: 2005
Mounting surface: 4401-05-05-0-05 (see table P005)
 Fastening bolts: 4 socket head screws M6x40 class 12.9
 Tightening torque = 15 Nm
 Seals: 5 OR 2050; 2 OR 108
 Diameter of ports A, B, P, T: \varnothing = 11 mm;
 Diameter of ports X, Y: \varnothing = 5 mm;

DPHW-1

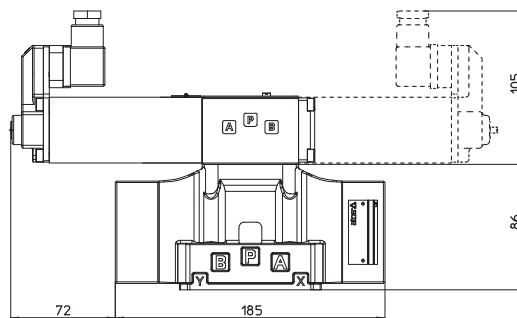

ISO 4401: 2005
Mounting surface: 4401-07-07-0-05 (see table P005)
 Fastening bolts:
 4 socket head screws M10x50 class 12.9
 Tightening torque = 70 Nm
 2 socket head screws M6x40 class 12.9
 Tightening torque = 15 Nm
 Seals: 4 OR 130; 3 OR 109/70
 Diameter of ports A, B, P, T: \varnothing = 20 mm;
 Diameter of ports X, Y: \varnothing = 7 mm;

DPHW-2

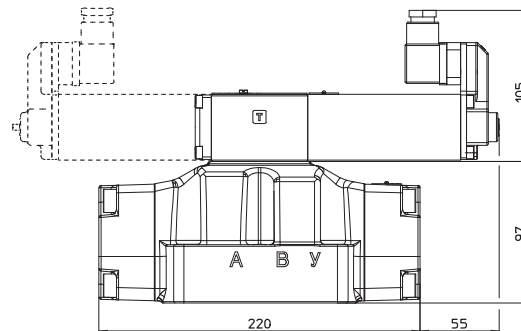

ISO 4401: 2005
Mounting surface: 4401-08-08-0-05 (see table P005)
 Fastening bolts:
 6 socket head screws M12x60 class 12.9
 Tightening torque = 125 Nm
 Seals: 4 OR 4112; 2 OR 3056
 Diameter of ports A, B, P, T: \varnothing = 24 mm;
 Diameter of ports X, Y: \varnothing = 7 mm;

DPHW-4

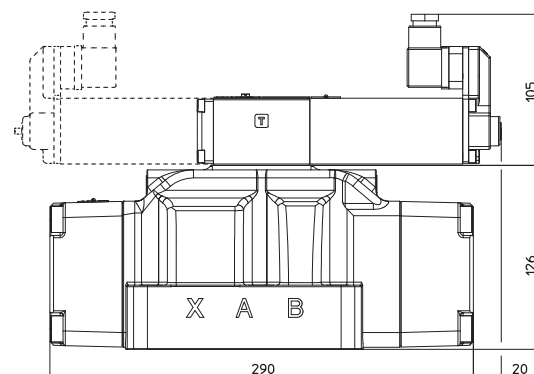

ISO 6264: 2007

Mounting surface: 6264-06-09-1-97

Fastening bolts:

4 socket head screws M12x35 class 12.9

Tightening torque = 125 Nm

Seals: 2 OR 123; 1 OR 109/70

Ports P, T: $\varnothing = 14,5$ mm

Ports X: $\varnothing = 3,2$ mm

AGAM-10

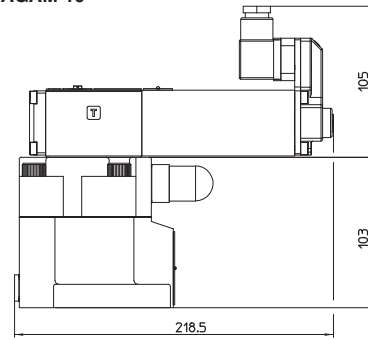

ISO 6264: 2007

Mounting surface: 6264-08-11-1-97

Fastening bolts:

4 socket head screws M16x50 class 12.9

Tightening torque = 300 Nm

Seals: 2 OR 4112; 1 OR 109/70

Ports P, T: $\varnothing = 24$ mm

Ports X: $\varnothing = 3,2$ mm

AGAM-20

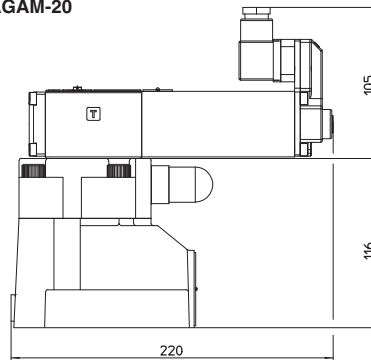

ISO 6264: 2007

Mounting surface: 6264-10-17-1-97

(with M20 fixing holes instead of standard M18)

Fastening bolts:

4 socket head screws M20x60 class 12.9

Tightening torque = 600 Nm

Seals: 2 OR 4131; 1 OR 109/70

Ports P, T: $\varnothing = 28,5$ mm

Ports X: $\varnothing = 3,2$ mm

AGAM-32

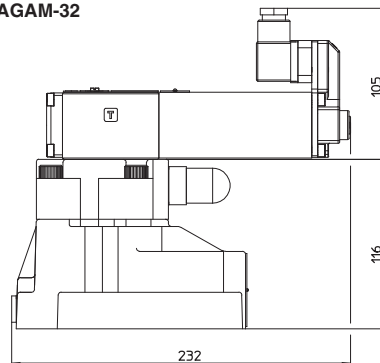

ARAM-20

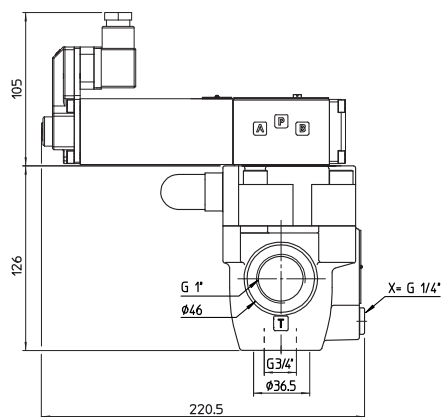

ARAM-32

